

Salad Dressing Factory (Ken's Foods)

Ken's Foods, a salad dressing and barbecue source producer in Massachusetts, USA, chose the AnMBR process as a means of upgrading its existing wastewater treatment plant to better handle suspended solids and provide treatment capacity for future production expansion. The existing wastewater treatment plant included raw wastewater primary pretreatment (screening, oil skimming and equalization), a low-rate anaerobic (ADI-BVF® Type 'S') reactor, and ADI-SBR. The existing anaerobic effluent contained significant TSS concentrations, which caused difficulty with aerobic polishing in the existing SBR, including sludge settleability and solids management. Upgrading the existing anaerobic system to AnMBR provided complete solids-liquid separation of the anaerobic effluent and a 60 percent increase in operating capacity while meeting the current effluent BOD5 and TSS limits of less than 180 and 230 kg/d (400 and 500 lb/d), respectively. Ken's Foods' wastewater is characterised as high-strength industrial wastewater with average COD, BOD, TSS, and FOG concentrations of 34,000 mg/l, 18,000 mg/l, 11,000 mg/l, and 1,500 mg/l, respectively. The high TSS and FOG concentrations ruled out high-rate anaerobic technologies as potential alternatives, unless significant investments were made in primary systems for removing these constituents prior to anaerobic treatment.

Following a successful operation of an AnMBR pilot system on site between Sep 2007 and Mar 2008, the full-scale AnMBR system was commissioned in July 2008. The AnMBR system consistently produces a high quality anaerobic effluent with BOD and TSS concentrations less than 25 mg/l and 2 mg/l, respectively, corresponding to essentially 100 percent removals. The system also provided complete digestion of the raw wastewater fat, oil, and grease concentrations, providing for further biogas generation and better management of biomass and suspended solids concentration. Note from the average effluent data that the effluent limits were consistently met for all effluent criteria. The anaerobic membrane tanks include 7 ES200 Kubota submerged membrane units per tank.



Photo of the four covered AnMBR tanks(left) and the membrane units inside the tank (right)

【Outline of the Facility】

Location :	Massachusetts, USA
Type of wastewater :	Salad dressing and barbecue source factory wastewater
Flow :	310 m ³ /d (peak flow 450 m ³ /d during peak production period Feb-May)
Commissioned :	July, 2008

Salad Dressing Factory (Ken's Foods)

【AnMBR Process Flow Sheet】

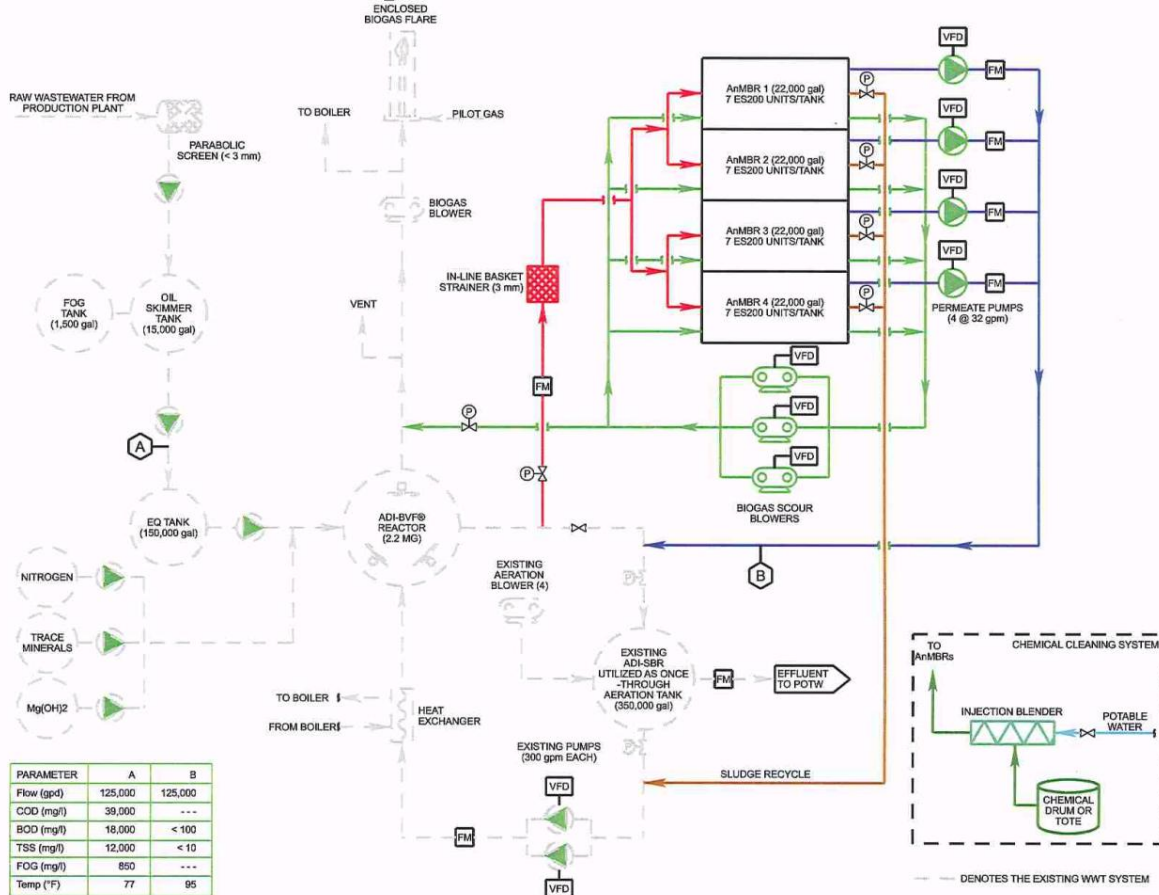

【Design Parameter and Actual Data】

Parameter	Influent	Effluent	
	Raw water	AnMBR Effluent (actual)	Discharge limits
BOD (mg/L), BOD (kg/d)	18,000, 8,600	20 7.0	- < 180
COD _{Cr} (mg/L), COD _{Cr} (kg/d)	34,000, 18,500	225 70	- -
TSS (mg/L), TSS (kg/d)	11,000, 5,700	<1 <1	- < 230
FOG (mg/L)	1,500	<5	<100

KUBOTA Corporation

Water Engineering & Solution Division
 Membrane Systems Sales Dept.
<http://www.kubota.co.jp>

Tokyo Head Office : 1-3, Nihombashi-Muromachi
 3-Chome, Chuo-ku, Tokyo 103-8310, Japan
 Tel:+81(0) 3-3245-3665 Fax:+81(0) 3-3245-3407

Hanshin Office : 1-1-1 Hama, Amagasaki, Hyogo
 661-8567, Japan
 Tel:+81(0) 6-6470-5145 Fax:+81(0) 6-6470-5159

KUBOTA Membrane Europe Ltd. : 7c Suite,
 Elsinore House, 77 Fulham Palace Road, London, W6 8JA, UK
 Tel:+44(0) 20-8741-5262 Fax:+44(0) 20-8563-1616
<http://www.kubota-mbr.com>

KUBOTA Membrane USA Corporation
 14824 NE 95th Street, Bldg. 6 Redmond, WA 98052, USA
 Tel: +1-425-898-2858 Fax: +1-425-898-2853
<http://www.kubota-membrane.com>

ADI Systems Inc.
 1133 Regent St., Suite 300, Fredericton, NB, Canada E3B 3Z2
 Tel: +1-506-452-7307 Fax: +1-506-452-7308
<http://www.adisystemsinc.com>