

Kubota MBR Case Study

Brewery

New strict effluent limits for discharge into the Chesapeake Bay are being imposed as part of a five-state effort to reduce nutrient loadings. Industrial facilities that discharge treated effluent into the Chesapeake Bay watershed have been involved in upgrading their wastewater treatment plants to provide high levels of nitrogen (N) and phosphorus (P) removal to meet new strict discharge regulations enacted to protect and improve the water quality of the Chesapeake Bay.

In mid-2010, a new membrane bioreactor (MBR) system was commissioned at Shenandoah Brewery, located near Elkton, Virginia. ADI Systems Inc. was selected to provide the new MBR system with sludge dewatering as a complete design/build contract. The objective of the MBR process is to treat the existing anaerobic system effluent to provide a very high quality effluent with extremely low biochemical oxygen demand (BOD), total suspended solids (TSS), total nitrogen (TN), and total phosphorus (TP) concentrations prior to discharge to the Shenandoah River which flows into the Chesapeake Bay. The MBR system uses Kubota submerged membrane technology, with biological and chemical N and P removal to produce an effluent with BOD, TSS, NH₃-N, TN and TP concentrations less than 5, 2, 1, 4 and 0.30 mg/l, respectively.

The anaerobic zone of the new MBR selects for biological phosphorus removing bacteria, whereas the aeration and pre- and post-anoxic zones provide nitrification and denitrification. Aluminum sulfate is also included to remove phosphorus chemically. The four membrane tanks include Kubota submerged membrane units for solids-liquid separation and final effluent polishing prior to discharge to an existing chlorine contact process before final release to the Shenandoah River.



Photo of the ADI-BVF reactors (foreground), existing activated sludge system (center, background) and new ADI-MBR system (right, background)



Photo of the new ADI-MBR system: 4 Membrane Tanks with Kubota RW400 units

【Outline of the Facility】

Location :	Virginia, USA
Type of wastewater :	Brewery Wastewater
Flow :	9,462 m ³ /d
Commissioned :	June, 2010

Kubota MBR Case Study

Brewery

【MBR Process Flow Sheet】

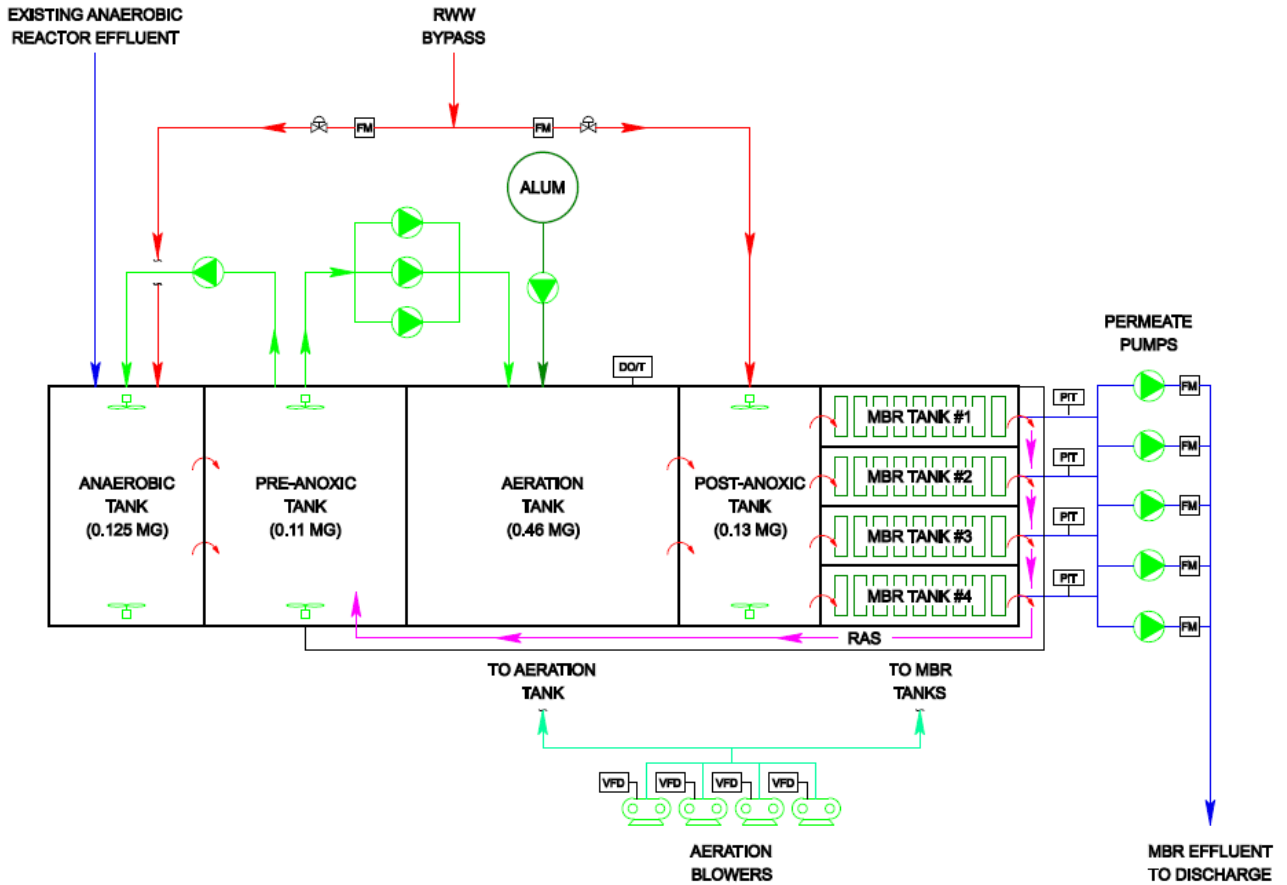

【Design Parameter and Actual Data】

Parameter	Influent	Effluent	
	Raw water	Anaerobic Effluent	MBR Effluent
BOD (mg/L)	4,100	250	<5
COD _{Cr} (mg/L)	6,900	1,000	-
TSS (mg/L)	1,200	600	<2
TN (mg/L)	57	57	<4
TP (m ³ /d)	15	15	<0.3

KUBOTA Corporation

Water Engineering & Solution Division
 Membrane Systems Sales Dept.
<http://www.kubota.co.jp>

Tokyo Head Office : 1-3, Nihombashi-Muromachi
 3-Chome, Chuo-ku, Tokyo 103-8310, Japan
 Tel:+81(0) 3-3245-3665 Fax:+81(0) 3-3245-3407

Hanshin Office : 1-1-1 Hama, Amagasaki, Hyogo
 661-8567, Japan
 Tel:+81(0) 6-6470-5145 Fax:+81(0) 6-6470-5159

KUBOTA Membrane Europe Ltd. : 7c Suite,
 Elsinore House, 77 Fulham Palace Road, London, W6 8JA, UK
 Tel:+44(0) 20-8741-5262 Fax:+44(0) 20-8563-1616
<http://www.kubota-mbr.com>

KUBOTA Membrane USA Corporation
 14824 NE 95th Street, Bldg. 6 Redmond, WA 98052, USA
 Tel: +1-425-898-2858 Fax: +1-425-898-2853
<http://www.kubota-membrane.com>

ADI Systems Inc.
 1133 Regent St., Suite 300, Fredericton, NB, Canada E3B 3Z2
 Tel: +1-506-452-7307 Fax: +1-506-452-7308
<http://www.adisystemsinc.com>